

<b>rubinetti</b>	2
taps/Hähne/robinets	
<b>accessori</b>	19
accessories/Accessories/accessoires	
<b>caratteristiche tecniche</b>	24
physical properties/technische Daten/caractéristiques techniques	
<b>garanzie prodotti</b>	26
warranty/Garantie/garantie	
<b>manutenzione prodotti</b>	27
maintenance/Wartung/entretien	
<b>certificazioni</b>	28
certifications/Bescheinigung/certifications	
<b>condizioni generali di vendita</b>	30
general terms of sale/allgemeine Geschäftsbedingungen/conditions générales de vente	

	<p><b>XT7501200000</b></p> <p><b>370,00 €</b></p>	<p><b>XT750120NN00</b></p> <p><b>481,00 €</b></p>	<p><b>XT750120KS00</b></p> <p><b>740,00 €</b></p>	
--	---	---	---	--

**Monocomando lavabo/Single-lever washbasin mixer/Waschtischeinhebelmischer/Mitigeur de lavabo**

	<p><b>XT7503200000</b></p> <p><b>435,00 €</b></p>	<p><b>XT750320NN00</b></p> <p><b>566,00 €</b></p>	<p><b>XT750320KS00</b></p> <p><b>870,00 €</b></p>	
--	---	---	---	--

**Monocomando lavabo da piano/Single-lever washbasin mixer for top/Waschtischeinhebelmischer/Mitigeur de lavabo**

	<p><b>XT7502200000</b></p> <p><b>405,00 €</b></p>	<p><b>XT750220NN00</b></p> <p><b>527,00 €</b></p>	<p><b>XT750220KS00</b></p> <p><b>810,00 €</b></p>	
--	---	---	---	--

**Monocomando lavabo/Single-lever washbasin mixer/Waschtischeinhebelmischer/Mitigeur de lavabo**

	<p><b>XT7512200000</b></p> <p><b>408,00 €</b></p>	<p><b>XT751220NN00</b></p> <p><b>530,00 €</b></p>	<p><b>XT751220KS00</b></p> <p><b>816,00 €</b></p>	
--	---	---	---	--







**Monocomando lavabo incasso verticale completo/Complete vertical concealed single-lever washbasin mixer/ Kompletter Vertikalen UP-Waschtischeinhebelmischer/Mitigeur de lavabo vertical à encastrer, complète**

	<p><b>XT7511200000</b></p> <p><b>438,00 €</b></p>	<p><b>XT751120NN00</b></p> <p><b>596,00 €</b></p>	<p><b>XT751120KS00</b></p> <p><b>876,00 €</b></p>	
--	---	---	---	--

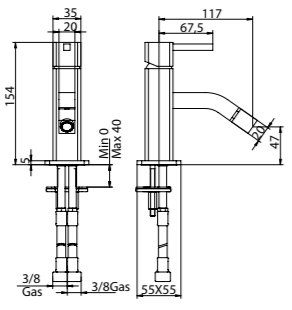
**Monocomando lavabo incasso completo/Complete concealed single-lever washbasin mixer/ Kompletter UP-Waschtischeinhebelmischer/Mitigeur de lavabo à encastrer, complète**

	<p><b>XT7504200000</b></p> <p><b>425,00 €</b></p>	<p><b>XT750420NN00</b></p> <p><b>553,00 €</b></p>	<p><b>XT750420KS00</b></p> <p><b>850,00 €</b></p>	
--	---	---	---	--

**Monocomando lavabo da piano/Single-lever washbasin mixer for top/Waschtischeinhebelmischer/Mitigeur de lavabo**

Finitura/Finishing/Finish/Finitions:	Cromo/Chrome Chrom/Chrome	Nero Opaco/Matt Black Matt Schwarz/Noir Mat	Oro Satinato/Satin Gold Satinier Gold/Or Satiné	
 	<b>XT7521200000</b>	<b>XT752120NN00</b>	<b>XT752120KS00</b>	     
	<b>370,00 €</b>	<b>481,00 €</b>	<b>740,00 €</b>	







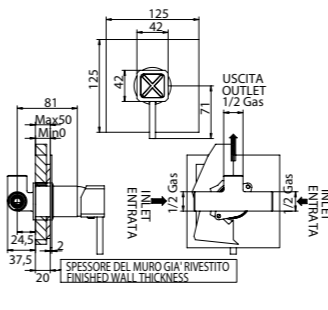

**Monocomando bidet/Single-lever bidet mixer/Bideteinhebelmischer/Mitigeur de bidet**

 	<b>XT7546200000</b>	<b>XT754620NN00</b>	<b>XT754620KS00</b>	      
	<b>370,00 €</b>	<b>481,00 €</b>	<b>740,00 €</b>	







**Monocomando vasca-doccia incasso completo/Complete concealed single-lever bathtub/shower control/  
Komplette UP-Brause und Wanneneinhebelmischer/Mitigeur de baignoire/douche à encastrer, complète**

 	<b>XT8549200000D</b>	<b>XT854920NN00D</b>	<b>XT854920KS00D</b>	          
	<b>515,00 €</b>	<b>670,00 €</b>	<b>1.030,00 €</b>	

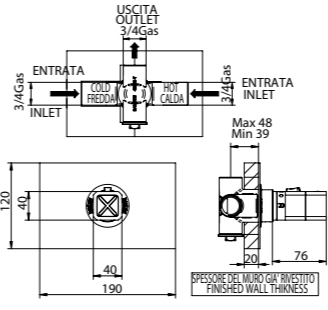









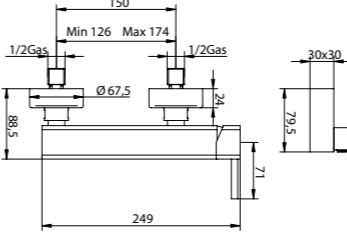

**Termostatico incasso doccia+deviatore d'arresto a 3 uscite, completo/Complete concealed shower thermostatic mixer with stopdiverter, 3-way-out/  
Komplette UP Dusche-Thermostat Mischer mit Absperrung Umsteller und 3 Ausläufe/Thermostatique de douche à encastrer avec inverseur d'arrêt à 3 sorties, complète**

Finitura/Finishing/Finish/Finitions:	Cromo/Chrome Chrom/Chrome	Nero Opaco/Matt Black Matt Schwarz/Noir Mat	Oro Satinato/Satin Gold Satinier Gold/Or Satiné	
 	<b>XT7541200000</b>	<b>XT754120NN00</b>	<b>XT754120KS00</b>	      
	<b>265,00 €</b>	<b>345,00 €</b>	<b>530,00 €</b>	

**Monocomando doccia incasso completo/Complete concealed single-lever shower control/  
Kompletter UP-Brauseeinhebelmischer/Mitigeur de douche à encastrer, complète**

 	<b>XT8549200000R</b>	<b>XT854920NN00R</b>	<b>XT854920KS00R</b>	     
	<b>295,00 €</b>	<b>384,00 €</b>	<b>590,00 €</b>	

**Termostatico incasso doccia completo/Complete concealed shower thermostat control/  
Kompletter UP-3/4" Thermostatmischer für Dusche/Thermostatique de douche à encastrer, complète**

 	<b>XT7581200000</b>	<b>XT758120NN00</b>	<b>XT758120KS00</b>	          
	<b>560,00 €</b>	<b>728,00 €</b>	<b>1.120,00 €</b>	

**Monocomando doccia esterno completo/Single-lever wall mtd shower set/  
Brauseeinhebelmischer mit Handbrause und Brausehalter/Mitigeur de douche externe sans kit de douche**

	<p><b>XT7551200000</b></p> <p><b>647,00 €</b></p>	<p><b>XT755120NN00</b></p> <p><b>841,00 €</b></p>	<p><b>XT755120KS00</b></p> <p><b>1.294,00 €</b></p>	
--	---	---	---	--

**Monocomando vasca esterno completo/Single-lever wall mtd bathtub set/ Wanneneinhebelmischer mit Duschgarnit und Handbrause/Mitigeur de baignoire externe complet**

	<p><b>XT7664400000</b></p> <p><b>1.390,00 €</b></p>	<p><b>XT766440NN00</b></p> <p><b>1.807,00 €</b></p>	<p><b>XT766440KS00</b></p> <p><b>2.780,00 €</b></p>	
--	---	---	---	--

**Monocomando bordo vasca 4 fori, completo di piastra e struttura installazione/Single-lever 4-hole deck mtd set, with plate and structure for installation/ Wannrandeinhebelmischer-4-Loch, mit Abdeckplatte und Tragesystem für Installation/Mitigeur bord de baignoire 4 trous, avec plaque en cuivre et structure pour installation**

	<p><b>XT7662400000</b></p> <p><b>800,00 €</b></p>	<p><b>XT766240NN00</b></p> <p><b>1.040,00 €</b></p>	<p><b>XT766240KS00</b></p> <p><b>1.600,00 €</b></p>	
--	---	---	---	--

**Monocomando bordo vasca 4 fori/Single-lever 4-hole deck mtd set/ Wannrandeinhebelmischer-4-Loch/Mitigeur bord de baignoire 4 trous**

	<p><b>XT7665400000</b></p> <p><b>570,00 €</b></p>	<p><b>XT766540NN00</b></p> <p><b>741,00 €</b></p>	<p><b>XT766540KS00</b></p> <p><b>1.140,00 €</b></p>	
--	---	---	---	--

**Monocomando bordo vasca 3 fori senza getto erogazione/Single-lever 3-hole deck mtd set without spout/ Wannrandeinhebelmischer-3-Loch, ohne Wanneneinlauf/Mitigeur bord de baignoire 3 trous à encastrer, sans jet**

	<p><b>XT78892000SF</b></p> <p><b>508,00 €</b></p>	<p><b>XT788920NNSF</b></p> <p><b>660,00 €</b></p>	<p><b>XT788920KSSF</b></p> <p><b>1.016,00 €</b></p>	
--	---	---	---	--

**Monocomando doccia esterno senza braccio e kit doccia/Single-lever wall mtd shower set without arm or shower kit/ Äußerer Einhebel-Brausemischer ohne Arm und Duschset/Une bar douche extérieur sans bras et équipement de douche**

Finitura/Finishing/Finish/Finitions:

**Cromo/Chrome**  
Chrom/Chrome

**Nero Opaco/Matt Black**  
Matt Schwarz/Noir Mat

**Oro Satinato/Satin Gold**  
Satinert Gold/Or Satiné

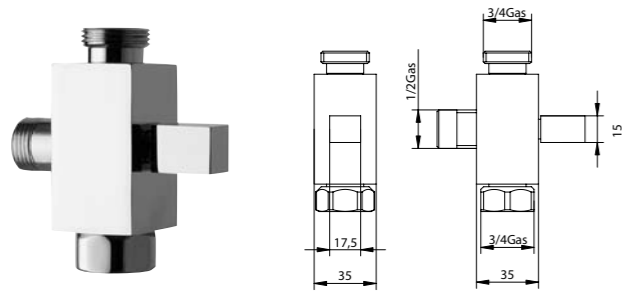

**XT00386834**

**70,00 €**

/

**XT0038683KS**

**140,00 €**

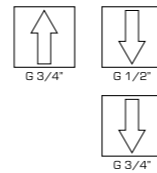

**Deviatore per asta doccia/Shower arm diverter/Umsteller für Brausearm/Inverseur pour tige de douche**

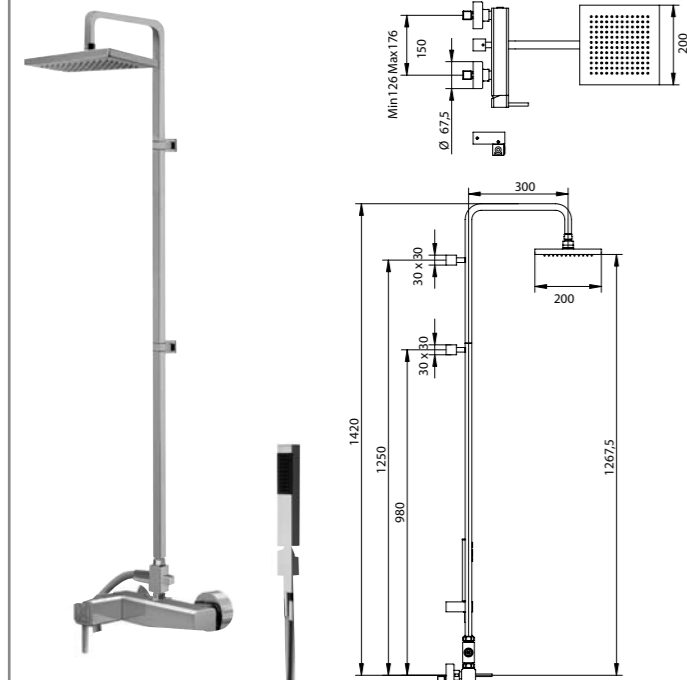

**XT7889200000**

**1.823,00 €**

**XT788920NN00**

**2.370,00 €**

**XT788920KS00**

**3.646,00 €**



**Monocomando doccia esterno con soffione e doccetta/Single-lever wall mtd shower set with shower head and handshower/ Brauseeinhebelmischer-Wellness, mit Kopf und Handbrause/Mitigeur de douche externe avec pommeau et douchette**

Finitura/Finishing/Finish/Finitions:

**Cromo/Chrome**  
Chrom/Chrome

**Nero Opaco/Matt Black**  
Matt Schwarz/Noir Mat

**Oro Satinato/Satin Gold**  
Satinert Gold/Or Satiné

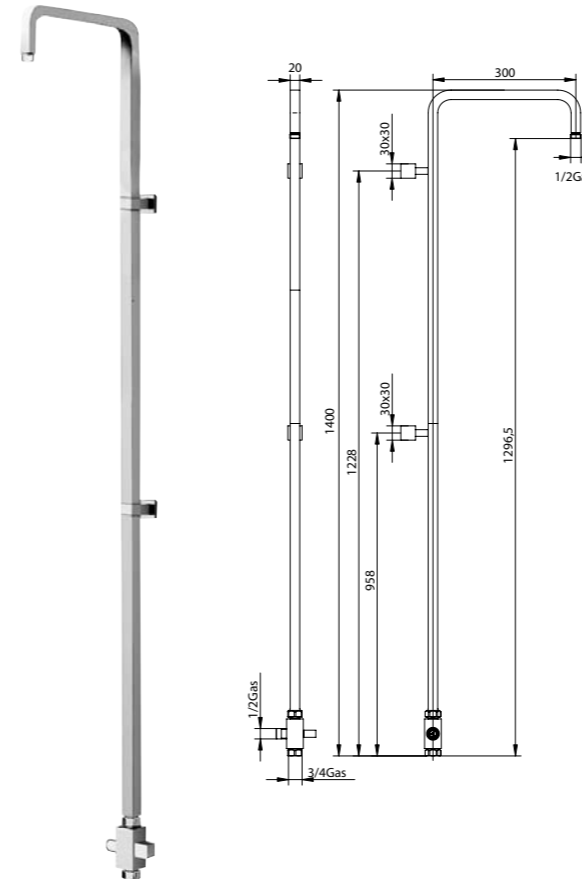

**XT00387614**

**690,00 €**

/

**XT0038761KS**

**1.380,00 €**

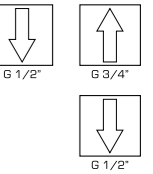

**Asta doccia con deviatore/Shower arm with diverter/Brausearm mit Umsteller/Tige de douche avec inverseur**

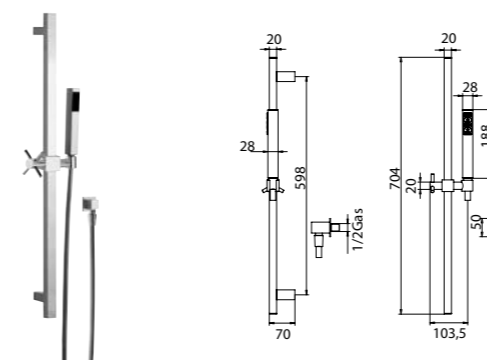

**XT7478200000**

**324,00 €**

/

**XT747820KS00**

**648,00 €**

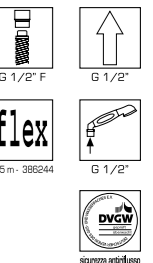



**Doccetta anticalcare 1 getto+asta saliscendi e presa acqua/Anti-limescale handshower, 1-jet, with slide bar and water supply attachment/ Brausegarnitur, 1-Strahl-Antikalk-Handbrause mit Wandanschlußbogen/Douchette 1 jet anti-calcaire avec tige télescopique et prise d'eau**

Finitura/Finishing/Finish/Finitions:





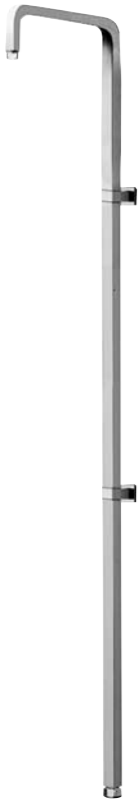
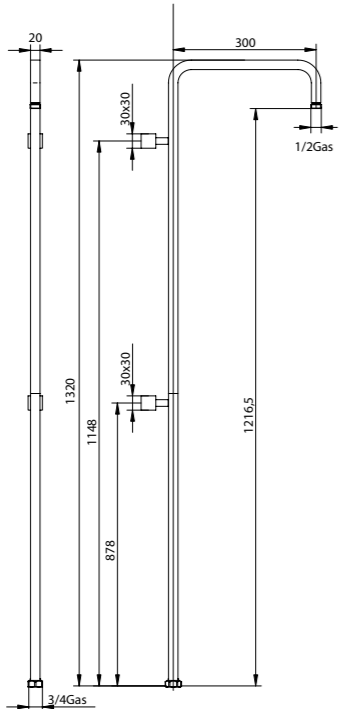

Cromo/Chrome  
Chrom/Chrome

Nero Opaco/Matt Black  
Matt Schwarz/Noir Mat

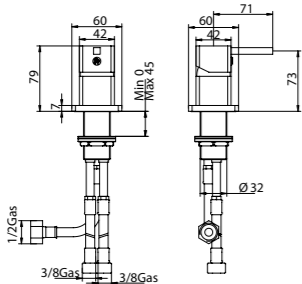
Oro Satinato/Satin Gold  
Satinert Gold/Or Satiné

 	<p><b>XT00387604</b></p> <p><b>622,00 €</b></p>	<p>/</p>	<p><b>XT0038760KS</b></p> <p><b>1.244,00 €</b></p>	 
---	---	----------	--	---

Asta doccia senza deviatore/Shower arm without diverter/Brausearm ohne Umsteller/Tige de douche sans inverseur

 	<p><b>XT8247400000</b></p> <p><b>265,00 €</b></p>	<p><b>XT824740NN00</b></p> <p><b>345,00 €</b></p>	<p><b>XT824740KS00</b></p> <p><b>530,00 €</b></p>	     
---	---	---	---	---



Comando remoto lavabo/vasca / Separate control for the washbasin/bathtub / Waschtischfischauslaufrohr-Wanneneinhebelmischer / Commande séparé pour bec lavabo/baignoire

Finitura/Finishing/Finish/Finitions:

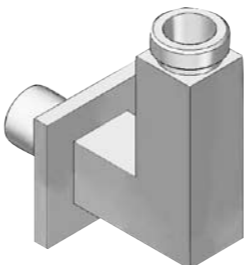
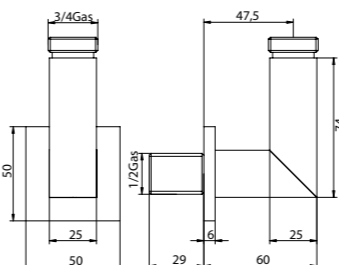

Cromo/Chrome  
Chrom/Chrome

Nero Opaco/Matt Black  
Matt Schwarz/Noir Mat



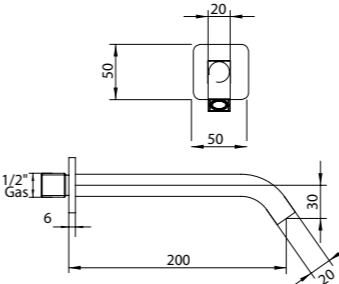

Oro Satinato/Satin Gold  
Satinert Gold/Or Satiné

 	<p><b>XT6491200000</b></p> <p><b>65,00 €</b></p>	<p>/</p>	<p><b>XT649120KS00</b></p> <p><b>130,00 €</b></p>	 
---	--	----------	---	---

Pres a acqua per asta doccia 1/2"x3/4" / Shower arm water supply attachment 1/2"x3/4" / Wandanschlußbogen für Brausearm 1/2"x3/4" / Prise d'eau pour tige de douche 1/2"x3/4"

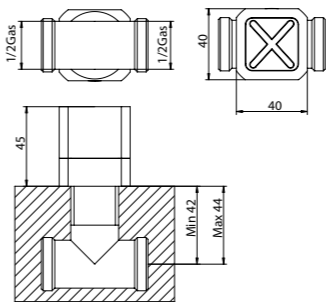
 	<p><b>XT6337200000</b></p> <p><b>165,00 €</b></p>	<p><b>XT633720NN00</b></p> <p><b>215,00 €</b></p>	<p><b>XT633720KS00</b></p> <p><b>330,00 €</b></p>	 
--	---	---	---	---

Getto erogazione/Wall mtd tub spot/Wandauslauf/Bec

 	<p><b>XT7567200000</b></p> <p><b>80,00 €</b></p>	<p><b>XT756720NN00</b></p> <p><b>104,00 €</b></p>	<p><b>XT756720KS00</b></p> <p><b>160,00 €</b></p>	   
---	--	---	---	---

Rubinetto incasso/Concealed tap/UP-Ventil/Robinet à encastrer

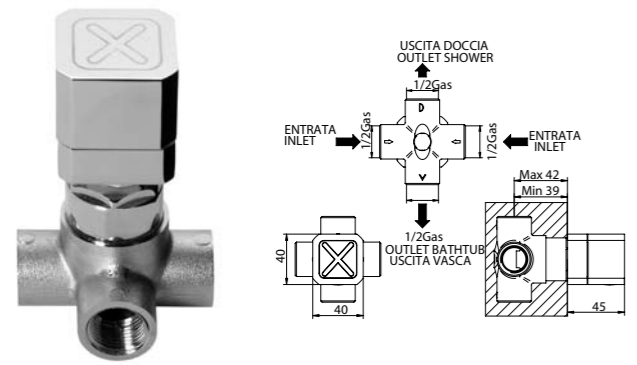
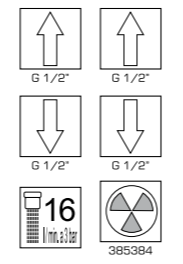
	<p><b>XT7537200000</b></p> <p><b>138,00 €</b></p>	<p><b>XT753720NN00</b></p> <p><b>179,00 €</b></p>	<p><b>XT753720KS00</b></p> <p><b>276,00 €</b></p>	
--	---	---	---	---

**Deviatore incasso a 4 vie/Concealed 4-way diverter/4-Wege Umsteller, UP/Inverseur à encastrer à 4 sorties**

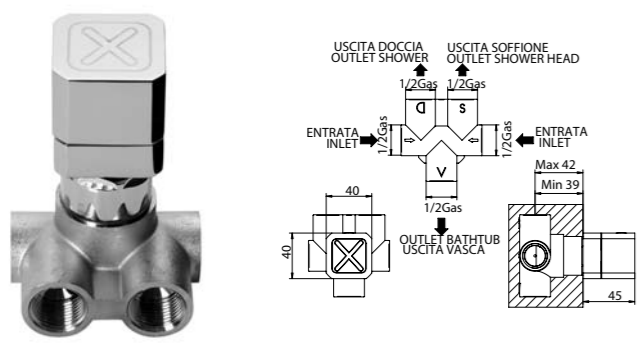
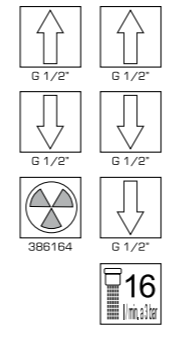
	<p><b>XT7557200000</b></p> <p><b>158,00 €</b></p>	<p><b>XT755720NN00</b></p> <p><b>205,00 €</b></p>	<p><b>XT755720KS00</b></p> <p><b>316,00 €</b></p>	
---	---	---	---	--

**Deviatore incasso a 5 vie con arresto/Concealed 5-way diverter with stopcock/5-Wege Umsteller, UP mit Absperrung/Inverseur à encastrer à 5 sorties avec arrêt**

	<p><b>XT00386644</b></p> <p><b>72,00 €</b></p>	<p>/</p>	<p><b>XT0038664KS</b></p> <p><b>144,00 €</b></p>	
--	--	----------	--	---

**Doccetta anticalcare 1 getto/Anti-limescale handshower 1 jet/Handbrause-1-Strahl-Antikalk/Douchette 1 jet anti-calcaire**

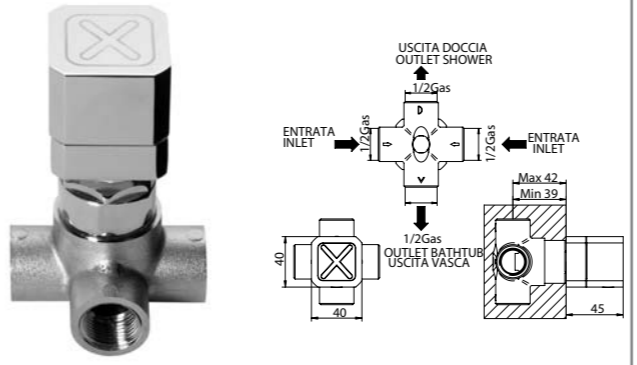
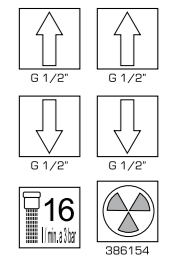
	<p><b>XT7537200000C</b></p> <p><b>139,00 €</b></p>	<p><b>XT753720NN00C</b></p> <p><b>181,00 €</b></p>	<p><b>XT753720KS00C</b></p> <p><b>278,00 €</b></p>	
---	--	--	--	---

**Deviatore incasso a 4 vie con arresto/Concealed 4-way diverter with stopcock/4-Wege Umsteller, UP mit Absperrung/Inverseur à encastrer à 4 sorties avec arrêt**

	<p><b>XT003915384</b></p> <p><b>135,00 €</b></p>	<p>/</p>	<p><b>XT00391538KS</b></p> <p><b>270,00 €</b></p>	
--	--	----------	---	--

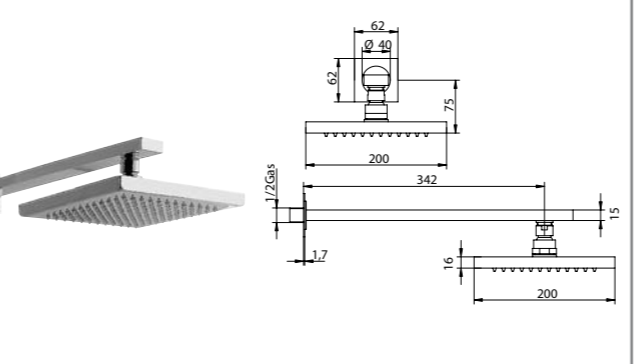
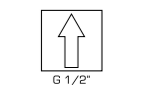

**Asta saliscendi/Slide bar/Brausegestänge/Tige télescopique**

	<p><b>XT6470100000</b></p> <p><b>490,00 €</b></p>	<p>/</p>	<p><b>XT647010KS00</b></p> <p><b>1.078,00 €</b></p>	
---	---	----------	---	---

**Braccio doccia con soffione anticalcare/Shower arm, anti-limescale shower head/Arm und Antikalk Kopfbrause/Bras de douche avec pommeau anti-calcaire**

	<p><b>XT00386904</b> <b>440,00 €</b></p>	<p>/</p>	<p><b>XT0038690KS</b> <b>968,00 €</b></p>	
--	--	----------	---	---

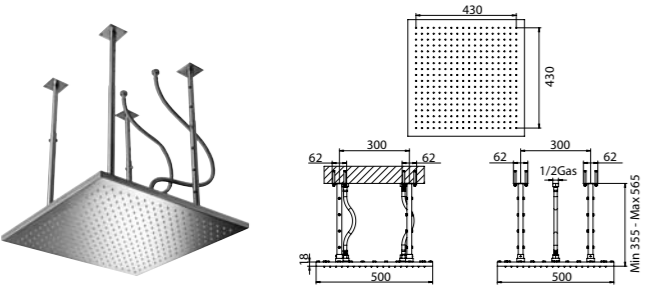

**Soffione con anticalcare/Anti-limescale shower head/Antikalk Kopfbrause/Pomme de douche anti-calcaire**

	<p><b>XT0038738IS4</b> <b>1.285,00 €</b></p>	<p>/</p>	<p>/</p>	
--	--	----------	----------	---

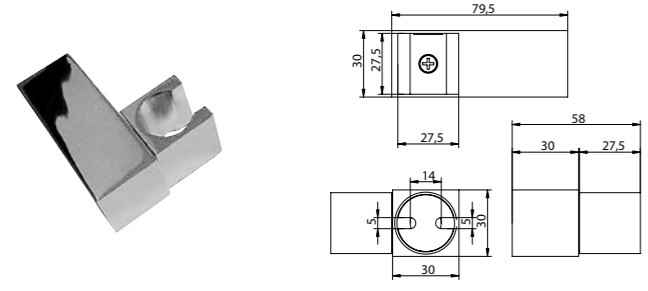

**Soffione doccia da soffitto acciaio inox/Ceiling shower head, stainless steel/Decken-Duschkopf aus rostfreiem Stahl/Plafond pomme de douche en acier inoxydable**

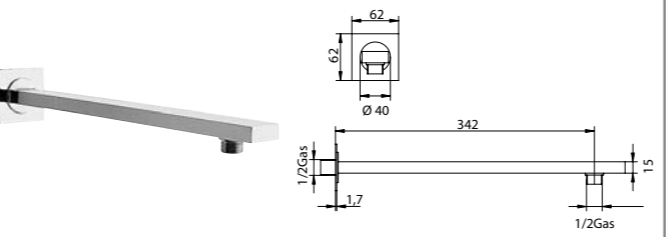
	<p><b>XT00387374</b> <b>58,00 €</b></p>	<p><b>XT0038737NN</b> <b>75,00 €</b></p>	<p><b>XT0038737KS</b> <b>116,00 €</b></p>	
--	---	--	---	--

**Attacco a snodo per doccetta/Swivel wall bracket for handshower/Brausehalter/Raccord de douchette articulé**

	<p><b>XT00100054</b> <b>75,00 €</b></p>	<p>/</p>	<p><b>XT0010005KS</b> <b>150,00 €</b></p>	
---	---	----------	---	---

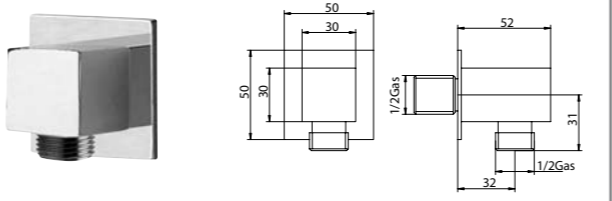
**Braccio doccia/Shower arm/Kopfbrausearm/Bras de douche**

	<p><b>XT00091814</b> <b>65,00 €</b></p>	<p><b>XT0009181NN</b> <b>85,00 €</b></p>	<p><b>XT0009181KS</b> <b>130,00 €</b></p>	
---	---	--	---	---

**Preso acqua/Water supply attachment/Wandanschlußbogen/Prise d'eau**

	<p><b>XT00386244</b> <b>48,00 €</b></p>	<p>/</p>	<p>/</p>	
---	---	----------	----------	---

**Flessibile in PVC F 1/2"xF 1/2" - 1,50 m/PVC flex hose, F 1/2"xF 1/2" - 1,50 m/PVC brauseschlauch F 1/2"xF 1/2"x1,50 m/Flexible en PVC, F 1/2"xF 1/2" - 1,50 m**

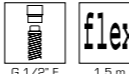
Finitura/Finishing/Finish/Finitions:		Cromo/Chrome Chrom/Chrome	Nero Opaco/Matt Black Matt Schwarz/Noir Mat	Oro Satinato/Satin Gold Satinert Gold/Or Satiné
	/	/	<b>XT003809KS</b> <b>96,00 €</b>	 G 1/2" F 1,5 m



**Flessibile in ottone F 1/2"xF 1/2"-1,50 m/Flexible in brass F 1/2"xF 1/2" - 1,50 m/Messing brauseschlauch F 1/2"xF 1/2"x1,50 m/ Flexible en laiton F 1/2"xF 1/2"-1,50 m**

		<b>XT00396304</b> <b>40,00 €</b>	<b>XT0039630NN</b> <b>52,00 €</b>	<b>XT0039630KS</b> <b>80,00 €</b>	
---	--	-------------------------------------	--------------------------------------	--------------------------------------	--

**Basettina porta doccia per bordo vasca/Shower bracket for deck mtd bathtub/Duschablagearm-Wannenrand, 1/2"-Konusaufnahme/ Base porte de douche pour bord de baignoire**

	<b>XT00386094</b> <b>60,00 €</b>	<b>XT0038609NN</b> <b>78,00 €</b>	<b>XT0038609KS</b> <b>120,00 €</b>	
---	-------------------------------------	--------------------------------------	---------------------------------------	--

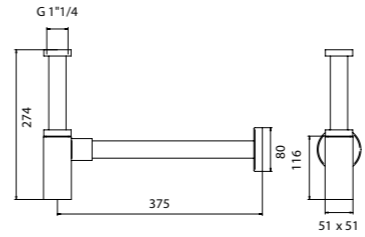
**Scarico automatico G 1 1/4 stop and go senza troppo pieno/Pop up waste stop and go 1 1/4 without over flow/Ablaufventil 1 1/4/ Vidage automatique 1 1/4 "stop and go" sans trop plein**

Finitura/Finishing/Finish/Finitions:		Cromo/Chrome Chrom/Chrome	Nero Opaco/Matt Black Matt Schwarz/Noir Mat	Oro Satinato/Satin Gold Satinert Gold/Or Satiné	
		<b>XT6772400000</b> <b>125,00 €</b>	/	<b>XT677240KS00</b> <b>250,00 €</b>	

**Sifone lavabo/Washbasin siphon/Waschtischsiphon 5/4"/Siphon de lavabo**

		<b>XT8823200000</b> <b>88,00 €</b>	<b>XT882320NN00</b> <b>114,00 €</b>	<b>XT882320KS00</b> <b>176,00 €</b>	
---	--	---------------------------------------	--	--	--

**Rubinetto d'arresto con filtro/Stopcock with filter/Eckventil mit Filter/Robinet d'arrêt avec filtre**

I prodotti sono tutti disponibili con finitura **CROMO (OO)**, trattamento galvanico con Nichel e Cromo in quantità superiore a quanto previsto dalle normative Europee. E su richiesta, (consegna 60/90 giorni) nelle finiture:

**ORO SATINATO (KS)**, oro 24 carati galvanizzato con protezione trasparente satinata.

**NERO OPACO (NN)**, smaltatura con vernice epossidica cotta in forno a 200°.

The products are all available with **CROMO (OO)** finishing, a galvanic treatment with an amount of Nickel and Chromium above EU normative indications. The products are available on request (delivery in 60/90 days) in the following finishes:

**SATIN GOLD (KS)**, 24 carats gold galvanized with a satin transparent protection.

**MATT BLACK (NN)**, glazing with epoxy paint fired in oven at 200°C.

Alle Produkte sind lieferbar in **CHROM (OO)**, Finish nach einer galvanischen Behandlung mit Nickel und Chrom in höheren Mengenanteilen als sie durch die europäischen Normen vorgeschrieben werden. Die Produkte sind auf Anfrage (Lieferung 60-90 Tage) in den folgenden Verarbeitungen lieferbar:





**GOLD SATINIERT (KS)**, 24-karätiges Gold, mit einem transparenten Schutzbelag galvanisch behandelt.

**MATT-SCHWARZ (NN)**, Epoxydlackierung, bei 200°C im Ofen behandelt.

Les produits sont tous disponibles avec la finition **CROMO (OO)**, un traitement galvanique avec un quantitative de Nickel et Chrome supérieur que celui prévu par les normes Européennes. Les produits sont disponibles sur demande (livraison 60/90 jours) dans les finitions:

**OR SATINE (KS)**, or 24 carats galvanisé avec protection transparente satinée

**NOIR OPAQUE (NN)**, vernissage avec vernis époxy cuit au four à 200° C.

	<p><b>0000383885</b></p> <p><b>20,00 €</b></p>	<ul style="list-style-type: none"> <li>- Cartucce di tipo chiuso</li> <li>- Diametro 25 mm</li> <li>- Rotazione leva di apertura 25°</li> <li>- Rotazione leva di miscelazione 100°</li> <li>- Tenuta a pressione statiche 30 bar</li> <li>- Shock termici da 5° C a 90° C max sopportabile</li> </ul> <ul style="list-style-type: none"> <li>- Geschlossene Kartusche</li> <li>- 25 mm Durchmesser</li> <li>- Öffnung Rotation des Hebels 25°</li> <li>- Mischstellung des Hebels 100°</li> <li>- Abdichtung bei statischem Druck von 30bar</li> <li>- Thermischer Shock von 5°C bis zu 90°C</li> </ul>
<p><b>Cartuccia ceramica comando a leva/Ceramic cartridge lever command/ Keramikkartusche/Cartouche en céramique, commande à levier</b></p>		
	<p><b>0000375614</b></p> <p><b>68,00 €</b></p>	<ul style="list-style-type: none"> <li>- Rotazione della manopola 330° angolari</li> <li>- Blocco di sicurezza 38° C</li> <li>- Campo di lavoro da 5° C a 80° C</li> <li>- Differenziale termico consigliato 50° C</li> <li>- Campo di pressione in rete da 1 a 10 bar (consigliato da 1 a 5 bar dinamici)</li> <li>- Sistema di sicurezza con blocco dell'erogazione in caso di mancanza di una delle due acque</li> <li>- Alta erogazione (circa 30 litri) in uscita libera con corpo ideale</li> <li>- Funzionamento sia con scaldabagni a gas che elettrici ad accumulo, impianti centralizzati, caldaie murali</li> <li>- Filtri in acciaio inox per il trattamento delle impurità.</li> <li>- Tutti i termostati vengono tarati in fabbrica a 38° C ± 1° C con differenziale termico di 50° C e acqua a 3 bar.</li> </ul> <ul style="list-style-type: none"> <li>- Reglers Rotation 330° im Winkel</li> <li>- Sicherheitsblock 38° C</li> <li>- Arbeitsbereich von 5° bis 80°C</li> <li>- Geratener Thermischer Differenzial 50° C</li> <li>- Leitung Druckfeld con 1 bis 10 bar dynamisch</li> <li>- Sicherheitssystem wobei der Wasserlauf beim Fehlen eines der beiden Wasserlaufe blockiert wird</li> <li>- Im idealer Situation ist ungefähr von 30 Liter</li> <li>- Funktioniert mit Gas sowie Elektro-Boiler, Warmwasserboiler, Zentrale Anlage</li> <li>- Edelstahl Filter für Wasserverschmutzung Behandlung.</li> <li>- Alle Thermostatische Mischer werden zwischen 38° C und ± 1° C geeicht, mit thermischer Differenzial von 50° C und 3 bar Wasser Druck.</li> </ul>
<p><b>Cartuccia termostatica/Thermostat cartridge/ Thermostatische Kartusche/Cartouche thermostatique</b></p>		
	<p><b>0000386454</b></p> <p><b>28,00 €</b></p>	<ul style="list-style-type: none"> <li>- Cartucce di tipo chiuso</li> <li>- Diametro 25 mm</li> <li>- Rotazione leva di apertura 25°</li> <li>- Rotazione leva di miscelazione 100°</li> <li>- Tenuta a pressione statiche 30 bar</li> <li>- Shock termici da 5° C a 90° C max sopportabile</li> </ul> <ul style="list-style-type: none"> <li>- Geschlossene Kartusche</li> <li>- 25 mm Durchmesser</li> <li>- Öffnung Rotation des Hebels 25°</li> <li>- Mischstellung des Hebels 100°</li> <li>- Abdichtung bei statischem Druck von 30 bar</li> <li>- Thermischer Shock von 5°C bis zu 90°C</li> </ul>
<p><b>Cartuccia ceramica comando a leva/Ceramic cartridge lever command/ Keramikkartusche/Cartouche en céramique, commande à levier</b></p>		
	<p><b>0000373084DX</b> <b>0000373084SX</b></p> <p><b>23,00 €</b></p>	<ul style="list-style-type: none"> <li>- Closed-cartridge</li> <li>- 25 mm diameter</li> <li>- Opening lever rotation 25°</li> <li>- Mixing lever rotation 100°</li> <li>- Seal at static pressure at 30 bar</li> <li>- Thermal shock from 5° C to 90° C max</li> </ul> <ul style="list-style-type: none"> <li>- Cartouche de type fermé</li> <li>- Diamètre 25 mm</li> <li>- Rotation du levier d'ouverture 25°</li> <li>- Rotation du levier de mélange 100°</li> <li>- Etanchéité à pression statique 30 bars</li> <li>- Chocs thermiques: de 5° à 90°C max</li> </ul>
<p><b>Vitone ceramico chiusura a 90°/90° Ceramic screw closure mechanism/ 90° Keramikoberteil/Cartouche céramique fermeture à 90</b></p>		



	<b>XT6955000000</b> <b>105,00 €</b>	<b>XT695500NN00</b> <b>136,50 €</b>	<b>XT695500KS00</b> <b>210,00 €</b>
---	--	--	--

**Portasapone singolo da muro/Single wall-mounted soap dish/Seifenschale wandhaengend/Porte savon simple mural**

	<b>XT6957000000</b> <b>125,00 €</b>	<b>XT695700NN00</b> <b>162,50 €</b>	<b>XT695700KS00</b> <b>250,00 €</b>
--	--	--	--

**Dispenser sapone in acciaio/Steel soap dispenser/Seifenspender aus Stahl/Distributeur de savon en acier**

	<b>XT6964000000</b> <b>118,00 €</b>	<b>XT696400NN00</b> <b>153,40 €</b>	<b>XT696400KS00</b> <b>236,00 €</b>
---	--	--	--

**Portabicchiere da muro/Wall-mounted cup holder/Becherhalter für die Wand/Porte-verre mural**

	<b>XT6997100000</b> <b>94,00 €</b>	<b>XT699710NN00</b> <b>122,20 €</b>	<b>XT699710KS00</b> <b>188,00 €</b>
---	---------------------------------------	--	--

**Griglia portasapone doppia/Double soap rack/Doppelte Seifenschale/Porte-savon double grille**

	<b>XT6998400000</b> <b>75,00 €</b>	<b>XT699840NN00</b> <b>97,50 €</b>	<b>XT699840KS00</b> <b>150,00 €</b>
--	---------------------------------------	---------------------------------------	--

**Griglia portasapone singola/Single soap rack/Seifenschale/Porte-savon grille simple**

	<b>XT6972000000</b> <b>47,00 €</b>	<b>XT697200NN00</b> <b>61,10 €</b>	<b>XT697200KS00</b> <b>94,00 €</b>
---	---------------------------------------	---------------------------------------	---------------------------------------

**Appendiabito da muro/Wall clothes hanger/Wandkleiderhaken/Portemanteau mural**

	<b>XT6949000000</b>  95,00 €	<b>XT694900NN00</b>  123,50 €	<b>XT694900KS00</b>  190,00 €
---	------------------------------------	-------------------------------------	-------------------------------------

**Portasciugamano da mobile 45 cm/Furniture towel rail 45 cm/Handtuchhalter für Badmöbel 45 cm/Porte-serviette pour le meuble 45 cm**

	<b>XT6946000000</b>  125,00 €	<b>XT694600NN00</b>  162,50 €	<b>XT694600KS00</b>  250,00 €
--	-------------------------------------	-------------------------------------	-------------------------------------

**Portasciugamano da muro 60 cm/Towel rail 60 cm/Handtuchstange 60 cm/Porte serviette 60 cm**

	<b>XT6536000000</b>  125,00 €	<b>XT653600NN00</b>  162,50 €	<b>XT653600KS00</b>  250,00 €
---	-------------------------------------	-------------------------------------	-------------------------------------

**Portasciugamano ad anello da muro/Wall loop towel rack/Wandhandtuchring/Porte-serviette à anneau mural**

	<b>XT6996000000</b>  245,00 €	<b>XT699600NN00</b>  318,50 €	<b>XT699600KS00</b>  490,00 €
---	-------------------------------------	-------------------------------------	-------------------------------------

**Portasciugamano da hotel 60 cm/Hotel towel rail 60 cm/Handtuchhalter fuer Hotel 60 cm/Porte serviette d'Hotel 60 cm**

	<b>XT6914000000</b>  114,00 €	<b>XT691400NN00</b>  148,20 €	<b>XT691400KS00</b>  228,00 €
--	-------------------------------------	-------------------------------------	-------------------------------------

**Portarotolo da muro/Wall-mounted toilet roll/Wandrollenhalter/Porte-rouleau mural**

	<b>XT6924000000</b>  195,00 €	<b>XT692400NN00</b>  253,50 €	<b>XT692400KS00</b>  390,00 €
---	-------------------------------------	-------------------------------------	-------------------------------------

**Portascopino da terra/Free-standing toilet brush holder/WC-Buerste freistehend/Porte balai à poser**





















# caratteristiche tecniche / physical properties

 <b>Scarico automatico G 1"1/4</b> Automatic drain G 1"1/4 Exzenterventil 1"1/4 Vidage automatique 1"1/4 tour	 <b>Areatore M 16x1</b> Aerator M 16x1 Perlator M 16x1 Aerateur M 16x1	 <b>Aeratore snodato M 22x1</b> Swivel aerator M 22x1 Gelenkstück M 22x1 Aerateur articule M 22x1	 <b>Attacco flessibile M 15x1</b> Flex connector M 15x1 Schlauchanschluss M 15x1 Raccord flexible M 15x1
 <b>Scarico automatico G 1"1/4 stop and go</b> Automatic drain G 1"1/4 stop and go Ablaufventil 1"1/4 Vidage automatique 1"1/4 "stop and go"	 <b>Areatore M 22x1</b> Aerator M 22x1 Perlator M 22x1 Aerateur M 22x1	 <b>Cannette di rame foro 10 mm</b> Copper pipes, hole 10 mm Kupfer-anschlussrohre 10 mm Tuyau de raccordement en cuivre trou 10 mm	 <b>Attacco flessibile M 3/8"</b> Flex connector M 3/8" Schlauchanschluss M 3/8" Raccord flexible M 3/8"
 <b>Entrata acqua G 1/2"</b> G 1/2" water inlet Wassereingang 1/2" Entree eau de 1/2" tour	 <b>Areatore M 28x1</b> Aerator M 28x1 Perlator M 28x1 Aerateur M 28x1	 <b>Cannette di rame foro 8 mm</b> Copper pipes, hole 8 mm Kupfer-anschlussrohre 8 mm Tuyau de raccordement en cuivre trou 8 mm	 <b>Attacco flessibile M 1/2"x3/8"</b> Flex connector M 1/2"x3/8" Schlauchanschluss M 1/2"x3/8" Raccord flexible M 1/2"x3/8"
 <b>Entrata acqua da G 3/4"</b> G 3/4" water inlet 3/4 Wassereingang Entree eau de G 3/4"	 <b>Areatore M 18x1</b> Aerator M 18x1 Perlator M 18x1 Aerateur M 18x1	 <b>Flessibile sottolavabo</b> Under-basin flex hose Flexanschluss Schlauch Flexible sous lavabo	 <b>Doccetta con attacco da G 1/2"</b> Shower head with G 1/2" connector Kopfbrause mit 1/2" anschluss Douchette avec raccord de 1/2" tour
 <b>Entrata acqua 1"1/4</b> 1"1/4 water inlet Wassereingang 1"1/4 Entree eau 1"1/4	 <b>Areatore M 21,5x1</b> Aerator M 21,5x1 Perlator M 21,5x1 Aerateur M 21,5x1	 <b>Flessibile sottolavabo foro 8 mm</b> Under-basin flex hose hole 8 mm Flexanschluss Schlauch 8 mm Flexible sous lavabo trou 8 mm	 <b>Doccetta con attacco M 15x1</b> Shower head with M 15x1 connector Schlauchanschluss M 15x1 Douchette raccord M 15x1
 <b>Entrata acqua da G 3/8"</b> G 3/8" water inlet 3/8" Wassereingang Entree eau de G 3/8"	 <b>Areatore M 16,5x1</b> Aerator M 16,5x1 Perlator M 16,5x1 Aerateur M 16,5x1	 <b>Flessibile sottolavabo foro 10 mm</b> Under-basin flex hose hole 10 mm Flexanschluss Schlauch 10 mm Flexible sous lavabo trou 10 mm	 <b>Valvola antiriflusso</b> Anti-backflow valve Rückflussverhinderer Soupape anti retour
 <b>Entrata acqua da G 1"1/2</b> G 1"1/2 water inlet 1"1/2 Wassereingang Entree eau de 1"1/2 tour	 <b>Aeratore snodato M 18x1</b> Swivel aerator M 18x1 Gelenkstück M 18x1 Aerateur articule M 18x1	 <b>Flessibile sottolavabo foro 10 mm</b> Under-basin flex hose hole 10 mm Flexanschluss Schlauch 10 mm Flexible sous lavabo trou 10 mm	 <b>Interasse attacchi min 136 max 184 mm</b> Couplings centre-to-centre (min 136, max 184 mm) Stichmass (min 136, max 184 mm) Interaxe raccords (min 136 max 184 mm)
 <b>Uscita acqua da G 1/2"</b> G 1/2" water outlet Wasserausgang 1/2" Sortie eau de 1/2" tour	 <b>Aeratore snodato M 16,5x1</b> Swivel aerator M 16,5x1 Gelenkstück M 16,5x1 Aerateur articule M 16,5x1	 <b>Flessibile sottolavabo foro 8 mm</b> Under-basin flex hose hole 8 mm Flexanschluss Schlauch 8 mm Flexible sous lavabo trou 8 mm	 <b>Interasse attacchi min 126 max 174 mm</b> Couplings centre-to-centre (min 126, max 174 mm) Stichmass (min 126, max 174 mm) Interaxe raccords (min 126 max 174 mm)
 <b>Uscita acqua da G 3/4"</b> G 3/4" water outlet 3/4" Wasserausgang Sortie eau de G 3/4"	 <b>Aeratore snodato M 24x1</b> Swivel aerator M 24x1 Gelenkstück M 24x1 Aerateur articule M 24x1	 <b>Attacco flessibile G 1/2" F</b> Flex connector G 1/2" F Schlauchanschluss 1/2" Raccord flexible 1/2" F tour	 <b>Cartuccia ceramica</b> Ceramic cartridge Keramikkartusche Cartouche ceramique
 <b>Areatore M 24x1</b> Aerator M 24x1 Perlator M 24x1 Aerateur M 24x1	 <b>Aeratore snodato M 16x1</b> Swivel aerator M 16x1 Gelenkstück M 16x1 Aerateur articule M 16x1	 <b>Attacco flessibile M 15x1,25</b> Flex connector G 15x1,25 Schlauchanschluss M 15x1,25 Raccord flexible M 15x1,25	 <b>Cartuccia ceramica joystick</b> Joystick ceramic cartridge Joystick keramikkartusche Cartouche ceramique joystick

Note: La Bandini consiglia l'installazione di rubinetti filtro ispezionabili sulle due mandate per trattenere eventuali corpi estranei che potrebbero danneggiare gli organi di tenuta. La Bandini si riserva il diritto, ogni qualvolta si rendesse necessario, di apporre modifiche tecniche ed estetiche senza obbligo di preavviso.

Notes: Bandini advises installation of filters that can be inspected on both delivery circuits so as to trap foreign bodies that might damage seals/gaskets etc. Bandini reserves the right, whenever necessary, to make technical and aesthetic modifications without prior warning.

# technische Daten / caractéristiques techniques

 <b>Cartuccia ceramica</b> Ceramic cartridge Keramikkartusche Cartouche ceramique	 <b>Cartuccia ceramica joystick</b> Joystick ceramic cartridge Joystick keramikkartusche Cartouche ceramique joystick	 <b>flex Flessibile acciaio inox 1,50 m</b> Stainless steel flex hose 1.50 m Brauseschlauch-Edelstahl 1/2"x1/2"x1,50 m Flexible acier inox 1,50 m	 <b>Vitone ceramico chiusura a 90°</b> 90° large ceramic closure screw 90° keramikoberteil Croisillon ceramique fermeture a 90°
 <b>Cartuccia ceramica</b> Ceramic cartridge Keramikkartusche Cartouche ceramique	 <b>Cartuccia ceramica progressiva</b> Progressive ceramic cartridge Fortlaufende Keramikkartusche Cartouche ceramique progressive	 <b>flex Flessibile 1,00 m</b> Flex hose 1,00 m Brauseschlauch 1,00 m Flexible 1,00 m	 <b>Vitone ceramico chiusura 90°</b> 90° large ceramic closure screw 90° keramikoberteil Croisillon ceramique fermeture 90°
 <b>Cartuccia ceramica</b> Ceramic cartridge Keramikkartusche Cartouche ceramique	 <b>Cartuccia ceramica progressiva</b> Progressive ceramic cartridge Fortlaufende Keramikkartusche Cartouche ceramique progressive	 <b>flex Flessibile 1,50 m</b> Flex hose 1,50 m Brauseschlauch 1,50 m Flexible 1,50 m	 <b>Vitone ceramico chiusura 90°</b> 90° large ceramic closure screw 90° keramikoberteil Croisillon ceramique fermeture 90°
 <b>Cartuccia ceramica</b> Ceramic cartridge Keramikkartusche Cartouche ceramique	 <b>Cartuccia ceramica progressiva</b> Progressive ceramic cartridge Fortlaufende Keramikkartusche Cartouche ceramique progressive	 <b>flex Flessibile 2,00 m</b> Flex hose 2,00 m Brauseschlauch 2,00 m Flexible 2,00 m	 <b>Vitone ceramico chiusura 90° con inserto</b> 90° large ceramic closure screw with insert 90° keramikoberteil job-hotel Croisillon ceramique fermeture 90° avec insert
 <b>Cartuccia ceramica</b> Ceramic cartridge Keramikkartusche Cartouche ceramique	 <b>Cartuccia per singola acqua</b> Cartridge for one water Kartusche für eine einzelne Wasser Ausgang Cartouche pour une seule sortie d'eau	 <b>flex Flessibile 1,50 m</b> Flex hose 1,50 m Brauseschlauch 1,50 m Flexible 1,50 m	 <b>Vitone ceramico chiusura 180°</b> 180° large ceramic closure screw 180° keramikoberteil Croisillon ceramique fermeture 180°
 <b>Cartuccia ceramica</b> Ceramic cartridge Keramikkartusche Cartouche ceramique	 <b>flex Flessibile 1,50 m</b> Flex hose da 2,00 m Brauseschlauch M 15x1,25x1/2"x1,50 m Flexible 1,50 m	 <b>flex Flessibile 1,50 m</b> Flex hose 1,50 m Brauseschlauch 1,50 m Flexible 1,50 m	 <b>Vitone tradizionale</b> Traditional large screw Hahnoberteil Croisillon traditionnel
 <b>Cartuccia ceramica</b> Ceramic cartridge Keramikkartusche Cartouche ceramique	 <b>flex Flessibile da 2,00 m</b> Flex hose da 2,00 m Brauseschlauch 3/8"x1/2"x2,00 m Flexible de 2,00 m	 <b>flex Flessibile 1,50 m</b> Flex hose 1,50 m Brauseschlauch 1,50 m Flexible 1,50 m	 <b>Cartuccia ceramica per deviatore</b> Ceramic cartridge for diverter Keramikkartusche für umsteller Cartouche ceramique pour deviateur
 <b>Cartuccia ceramica</b> Ceramic cartridge Keramikkartusche Cartouche ceramique	 <b>flex Flessibile 1,50 m</b> Flex hose 1,50 m Brauseschlauch 1/2"x1/2"x1,50 m Flexible 1,50 m	 <b>Attacco vasca eccentrico G 1/2"xG 3/4"</b> Eccentric tub connector G 1/2"xG 3/4" S-anschluss 1/2"x3/4" Raccord excentrique baignoire 1/2"x3/4" tours	 <b>Cartuccia ceramica per deviatore</b> Ceramic cartridge for diverter Keramikkartusche für umsteller Cartouche ceramique pour deviateur
 <b>Cartuccia ceramica</b> Ceramic cartridge Keramikkartusche Cartouche ceramique	 <b>flex Flessibile 2,00 m</b> Flex hose 2,00 m Brauseschlauch M 15x1x1/2"x2,00 m Flexible de 2,00 m	 <b>Cartuccia termostatica</b> Thermostatic cartridge Thermostat-kartusche Cartouche thermostatique	 <b>INOX Acciaio INOX</b> Stainless steel Stahl Acier inox
 <b>Cartuccia ceramica joystick</b> Joystick ceramic cartridge Joystick keramikkartusche Cartouche ceramique joystick	 <b>flex Flessibile 1,5 m</b> Flex hose 1,50 m Brauseschlauch M 15x1x1/2"x1,50 m Flexible 1,50 m	 <b>Vitone ceramico chiusura 90°</b> 90° large ceramic closure screw 90° keramikoberteil Croisillon ceramique fermeture 90°	 <b>"Rubinetto Verde"</b> "Green Tap" "Grüne Armatur" "Robinet Vert"

Empfehlung: Bandini empfiehlt den Einbau von Eckventilen mit Filter, als Schutzmaß die Dichtungen und Kartusche beschädigen könnten gegen Fremdkörpern. Bandini hat das Recht sich ästhetische und technische Änderungen vorzunehmen wo sie nötig sind ohne vorzeitig zu informieren

Remarque: Bandini recommande l'installation de robinets disposant de filtres démontables sur les deux sorties afin de retenir d'éventuels corps étrangers qui pourraient nuire à l'étanchéité. Bandini se réserve le droit, chaque fois que cela est nécessaire, d'apporter des modifications techniques et esthétiques sans obligation de préavis.

**GARANZIA**

I prodotti Bandini, rigorosamente collaudati prima di essere posti in vendita, sono garantiti da difetti di fabbricazione per un periodo di 10 anni per le finiture cromo e zirconio e di 2 anni per tutte le altre finiture a partire dalla data di acquisto (farà fede la data della ricevuta di acquisto). L'usura delle cartucce ceramiche nei miscelatori monocomando, dei vitoni tradizionali e dei vitoni ceramici dipende dalla qualità dell'acqua: Bandini garantisce queste parti per 5 anni quando siano stati installati i rubinetti sottolavabo, vengano rispettati i valori di pressione di alimentazione consigliati e l'acqua presenti dei valori di durezza medi.

La garanzia comprende difetti di fusione, difetti di porosità e difetti di cromatura e consiste nella riparazione del pezzo riscontrato difettoso dopo la verifica da parte di Bandini e dietro presentazione della ricevuta d'acquisto.

La garanzia decade nel caso si riscontrino:

- Deterioramento delle superfici cromate dovuto all'uso di prodotti per la pulizia contenenti acidi o sostanze abrasive.
- Deterioramento delle superfici con finiture diverse da quelle cromate. La loro durata è infatti subordinata alla cura ed alla delicatezza d'uso da parte dell'utente.
- Deterioramento della rubinetteria imputabile ad installazione effettuata in modo non corretto.
- Utilizzo della rubinetteria in modo non corretto.
- Riparazione e manutenzione effettuate in modo non idoneo e senza preventiva autorizzazione dell'Azienda.

La garanzia non include le spese di manodopera per la sostituzione dei pezzi difettosi, né la richiesta di risarcimenti per danni diretti od indiretti subiti od insorti. La garanzia Bandini non è rinnovabile.

**WARRANTY**

All Bandini products are carefully tested before they are put on sale. Chrome and zirconium-finish products are guaranteed against production defects for 10 years while products with other finishes are guaranteed for 2 years as from the date of purchase date (as proven by receipt of payment). Wear on ceramic cartridges in single-lever mixers, traditional large screws and ceramic large screws depends on the quality of the water. Bandini guarantees these components for 5 years where a beneath-basin filter cock has been installed and where recommended water supply pressure is observed and water is of medium hardness.

The warranty covers casting defects, porosity defects and chrome-plating defects. We will repair or replace the faulty piece after examination and upon production of the receipt to confirm the purchase date.

The warranty does not apply to damage resulting from:

- Deterioration of chrome surfaces caused by the use of acid or abrasive cleaning products.
- Deterioration of surfaces with finishes other than chrome. Their lifespan depends on the care taken by the user.
- Improper installation.
- Improper use.
- Repair and maintenance carried out under unsuitable circumstances and without prior authorisation from Bandini.

The warranty does not include the labour charges incurred in replacing the faulty pieces, nor any claims for direct or indirect, damages suffered or arisen. The Bandini warranty cannot be renewed.

**GARANTIE**

Alle BANDINI Produkte werden geprüft bevor sie in den Verkauf kommen. Chrom- und Zirkoniumbeschichtete Produkte haben 10 Jahre Garantie für Produktionsfehler, während Produkte mit anderen Farbbeschichtungsflächen 2 Jahr Garantie ab dem Verkaufsdatum haben (RECHNUNGSDATUM). BANDINI gibt 5 Jahr Garantie auf die Keramikkartuschen sowie Keramikoberteile, wenn die Installation nach DIN 1988, Hauswasserstation eingebaut sind oder zu diesem Zeitpunkt nachweislich Installiert wurde Ein Wasserversorgungsdruck von 3,8 Bar darf nicht überschritten werden. Eine Wasserqualität mittlere Härte ist noch vertretbar Härtebereich 3.

Die Garantie bezieht sich auf Defekte, Porosität und Verchromungsdefekte. BANDINI wird das fehlerhafte Stück nach Prüfung des Sachverhaltes gegebenenfalls ersetzen, wobei das Rechnungsdatum mit berücksichtigt wird.

Die Garantie schließt folgendes nicht ein:

- BANDINI Armaturen müsse durch einen Fachhandwerker installiert werden.
- Beschädigung von Chrom- und Zirkonium Oberflächen, die durch die Verwendung von Säure oder Scheuermitteln bei der Reinigung verursacht wurden
- Beschädigung von Farbbeschichtungsflächen, verursacht durch die Verwendung von Säure oder Scheuermitteln bei der Reinigung.
- Fehlerhafte Installation
- Unzeckmäßige Verwendung.
- Reparatur durch nicht ausdrücklich autorisierten Fachhandwerksbetrieb von BANDINI

Die Garantie schließt die Arbeitskosten nicht ein, die zum Ersetzen der fehlerhaften Stücke anfallen, ebenso irgendwelche Behauptungen für direkt oder indirekt erlittenen Schäden, die entstanden sein sollen Die BANDINI Garantie kann nicht verlängert werden.

**GARANTIE**

Les produits Bandini sont testés rigoureusement avant leur mise en marché et sont garantis pendant 10 ans pour les finitions chrome et zirconium et de 2 ans pour toutes les autres finitions et ce à compter du jour d'achat (la date figurant sur le ticket d'achat faisant foi). L'usure des cartouches en céramique des mitigeurs, des cartouches traditionnelles et des cartouches en céramiques dépend de la qualité de l'eau : Bandini les garantira pendant 5 ans à condition que des valves d'arrêt de l'eau sous le lavabo aient été installées, que les valeurs de pression d'alimentation conseillées ont bien été respectées et que le niveau de dureté de l'eau est moyen.

La garantie couvre les défauts de fabrication, défaut de porosité et défaut de chromage et comprend la réparation de la pièce défectueuse après vérification de la société Bandini et sous présentation du ticket d'achat.

La garantie s'éteint dans les cas suivants :

- Détérioration des superficies chromées suite à l'utilisation de produits de nettoyage contenant de l'acide ou des substances abrasives.
- Détérioration des superficies autres que chromées. Leur durée de vie étant subordonnée aux soins et à la délicatesse avec laquelle les équipements sont utilisés.
- Détérioration de la robinetterie imputable à une installation incorrecte.
- Utilisation non appropriée de la robinetterie.
- Réparation et entretien non adapté et sans autorisation préalable de la société constructeur.

La garantie n'inclue pas les frais de main d'oeuvre pour le remplacement des pièces défectueuses ni la demande de dédommagement pour les dommages directs ou indirects subis ou occasionnés.

La garantie Bandini n'est pas renouvelable.

**MANUTENZIONE PRODOTTI**

Oggi la rubinetteria moderna dei sanitari, della cucina e delle docce, è prodotta con materiali molto differenti per soddisfare la richiesta del mercato riguardo al design ed alla funzionalità. Per evitare danni e reclami si devono considerare alcuni criteri durante l'uso e la pulizia dopo l'uso.

**Prodotti di pulizia per rubinetteria e docce**

- Gli acidi sono indispensabili come parte dei prodotti per la pulizia che eliminano forti depositi di calcare. Nella cura della rubinetteria e delle docce si devono considerare i seguenti punti:
- Utilizzare soltanto i prodotti di pulizia che sono destinati per il tipo di pulizia richiesto.
- Non utilizzare pulitori che contengano acido cloridrico, acido formico oppure acido acetico, perché questi possono creare gravi danni.
- Non utilizzare pulitori contenenti acido fosforico dove non indicato.
- Non utilizzare pulitori contenenti soluzioni cloridriche
- Non utilizzare mai miscele di diversi pulitori
- Non utilizzare prodotti abrasivi, come polveri abrasive, spugne e panni in microfibra.

**Istruzioni per la pulizia della rubinetteria e delle docce**

Seguire sempre le istruzioni d'uso dei produttori e dei mezzi di pulizia.

In generale:

- Pulire la rubinetteria e le docce solo quando necessario.
- Adattare le dosi del pulitore ed il tempo d'azione alle caratteristiche del prodotto e non lasciare mai agire il pulitore più del necessario.
- Evitare i depositi del calcare con la pulizia periodica.
- Non spruzzare mai il pulitore direttamente sulla rubinetteria, ma su un panno oppure una spugna, perché parte degli spruzzi possono infiltrarsi nelle aperture della rubinetteria e causare dei danni.
- Dopo la pulizia sciacquare bene con acqua per eliminare definitivamente i residui del prodotto di pulizia.

**Avvisi importanti**

Residui di creme, saponi, shampoo e gel doccia possono causare dei danni. Anche qui vale: dopo l'uso sciacquare bene con acqua per eliminare detti residui. Nelle superfici già danneggiate l'azione del prodotto di pulizia aumenta la progressione dei danni.

Danni a causa di trattamenti impropri non sono coperti dalla nostra garanzia.

**MAINTENANCE**

Modern sanitary tapware, kitchen mixers and showers consist of very different materials in order to meet the needs of the market with regard to design and functionality.

To avoid damages/claims it is necessary to consider certain criteria when cleaning.

**Cleaning materials for taps and showers**

Acids are necessary ingredients of cleaning materials as they remove lime. However, note the following points when cleaning mixers and showers:

- Only use cleaning materials explicitly intended for this type of application.
- Never use cleaning materials containing hydrochloric, formic or acetic acid, as they can cause considerable damage.
- Do not use materials containing phosphoric acid unless explicitly indicated.
- Never mix different cleaning materials together.
- Never use cleaning materials or appliances with an abrasive effect, such as unsuitable cleaning powders, sponge pads or micro fibre cloths.

**Cleaning instructions for taps and shower**

Please follow the cleaning material manufacturer's instructions. In addition observe the following:

- Clean mixers and shower as and when required.
- Use cleaning materials in doses that are suitable for the product and apply them for an appropriate length of time: do not let the cleaning material act on the product any longer than is necessary.
- Regular cleaning can prevent calcification.
- When using spray cleaners, spray first into a cloth or sponge, never directly into the sanitary tapware, as drops could enter openings and gaps and cause damage.
- After cleaning rinse thoroughly with clean water to remove any cleaning material residue.

**Important**

Residue from liquid soaps, shampoos and shower foam can also cause damage, so rinse with clean water after use.

If the surface is already damaged, the effect of cleaning materials will cause further damage.

Damage caused by improper treatment shall not be covered by our warranty.

**WARTUNG**

Moderne Sanitärartikel werden aus unterschiedlichen Materialien hergestellt, um den Bedürfnissen des Marktes in Hinsicht auf Design und Funktionalität zu entsprechen. Um Beanstandungen und Reklamationen zu vermeiden, ist es notwendig bestimmte Kriterien bei der Pflege zu beachten.

**Reinigung von Sanitärarmaturen und Produkten**

Säuren sind notwendige Bestandteile zum Reinigen von Sanitärmaterialien, da sie Kalk entfernen. Aber es ist folgendes zu beachten:

- Benutzen Sie Reinigungsmittel die eine neutrale Zusammensetzung haben, z.B. Neutralreiniger und Mikrofasertuch.
- Benutzen Sie keine Reiniger, die Salz, Ameisensäure, Phosphorsäure oder Essigsäure enthalten, da diese beträchtlichen Schaden verursachen können.
- Keine Scheuermittel oder dergleichen.
- Mischen Sie keine Reinigungsmittel zusammen.
- Benutzen Sie keine Reinigungsgegenstände mit ungeeigneter Oberfläche, Tücher mit rauer Oberfläche oder Scheuerschwämme, oder der Gleichen.

**Pflege von Sanitärarmaturen und Produkten**

Folgen Sie den Anweisungen des Herstellers des Reinigungsmittels. Beachten Sie außerdem folgende Punkte:

- Reinigen Sie die Sanitärarmaturen und Produkte nur bei Notwendigkeit.
- Beachten Sie bitte die Einwirkungszeit des Reinigungsmittels, und lassen Sie es nie länger als unbedingt notwendig einwirken, da es sonst Schäden verursachen kann.
- Durch sofortiges Abtrocknen nach Benutzung können Kalkablagerungen erheblich verhindern werden.
- Wenn Sie Sprühreiniger benutzen, sprühen Sie zuerst auf das Reinigungstuch und wischen dann ab, nie direkt auf die Sanitärarmaturen oder Produkte, da manche Reinigungsmittel dadurch Schäden an Dichtungen verursachen könnten.
- Nach dem Reinigen immer gründlich mit sauberem Wasser nachspülen und trocken wischen, um etwaige Rückstände von Reinigungsmitteln zu entfernen.

**Wichtig**

Rückstände von flüssiger Seife, Shampoos und Duschschaum können auch Schäden verursachen, spülen Sie deshalb immer mit sauberem Wasser nach Benutzung nach. Wenn die Oberfläche schon beschädigt ist, wird durch die Wirkung der Reiniger weiterer Schaden verursacht. SCHÄDEN DIE VON FALSCHER PFLEGE ODER INSTALLATION VERURSACHT WURDEN, SIND VON UNSERER GARANTIE AUSGESCHLOSSEN

**ENTRETIEN**

Aujourd'hui la robinetterie moderne destinée aux sanitaires, à la cuisine et aux douches, est fabriquée dans des matériaux très différents afin de répondre la demande de design et de fonctionnalité du marché.

Afin d'éviter tout dommage ou réclamation, il faut prendre certains critères en considération pendant l'utilisation et le nettoyage après utilisation.

**Produits de nettoyage pour robinetterie et douche**

Les produits à base d'acide sont admis dans les produits pour le nettoyage puisqu'ils permettent d'éliminer des dépôts de calcaire importants. Dans l'entretien de la robinetterie et des douches il faut se rappeler les points suivants : N'utiliser que les produits d'entretien qui sont conseillés pour le type d'utilisation souhaité. Ne pas utiliser de nettoyeurs qui contiennent de l'acide chlorhydrique, de l'acide formique ou de l'acide acétique car ils peuvent causer des dommages importants. Ne pas utiliser de nettoyeurs contenant de l'acide phosphorique lorsque cela n'est pas indiqué.

Ne pas utiliser de nettoyeurs contenant des solutions chlorhydriques. Ne jamais utiliser de mélange de certains de ces produits.

Ne pas utiliser de produits abrasifs, tels que des poudres abrasives, des éponges ou des chiffons en microfibras.

**Instructions pour le nettoyage de la robinetterie et de la douche**

Toujours suivre les instructions d'utilisation des produits et des moyens de nettoyage. En général :

- Ne nettoyer la robinetterie que lorsque cela est nécessaire.
- Adapter les doses de nettoyant et les temps d'action aux caractéristiques du produit et ne jamais laisser agir plus longtemps que la durée conseillée.
- Prévenir les dépôts de calcaire importants par un nettoyage régulier.
- Ne jamais vaporiser directement le nettoyant sur la robinetterie, mais sur un chiffon ou une éponge, car le nettoyant pourrait s'infiltrer dans les ouvertures de la robinetterie et entraîner des dommages.
- Bien rincer avec de l'eau après le nettoyage afin d'éliminer définitivement tous les résidus de nettoyeurs.

**Recommandations importantes**

Les résidus de crème, de savon, de shampooing et de gel douche peuvent entraîner des dommages. Il faut rincer soigneusement avec de l'eau après chaque utilisation. Sur les superficies déjà abîmées, l'action du produit de nettoyage va augmenter le développement de ces parties endommagées. Les dommages résultant de traitements impropres ne sont pas couverts pas notre garantie.

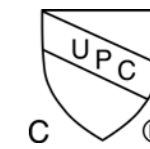
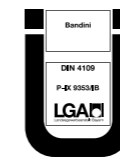
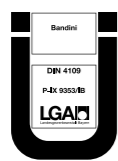

#### CERTIFICAZIONE RUBINETTO VERDE

I rubinetti Bandini offrono da sempre qualità, tecnologia, design, e contribuiscono a migliorare la salute. Perché sono sottoposti al sistema Ruveco ©\*\*, un trattamento che elimina il piombo dalla superficie delle parti in ottone del rubinetto. I test di controllo\*\*\* sull'acqua prelevata dai rubinetti trattati con il sistema Ruveco © hanno dimostrato un rilascio di piombo ben al di sotto di 10 microgrammi/litro (la soglia massima consigliata dall'OMS). Un risultato eccezionale, soprattutto se confrontato con quello dei rubinetti non trattati. Questi infatti rilasciano il piombo nella quantità di 100–120 microgrammi/litro.

Bandini Rubinetterie è tra le prime aziende in Europa ad utilizzare il trattamento, per offrire prodotti sicuri e all'avanguardia, ed è la prima azienda in Italia ad applicare il processo Ruveco © di depiombatura sistematicamente su tutti i prodotti\*.

\* Solo quelli con apposito logo.

\*\* Brevettato in Italia dal laboratorio di Ricerca e Sviluppo "Ruvaris", specializzato nello studio di nuove tecnologie da applicare a valvole e rubinetti.

\*\*\* Test effettuati dal laboratorio Ruvaris.

#### ENVIRONMENTALLY FRIENDLY TAPS CERTIFICATION

Bandini Rubinetterie has always offered you quality, technology and design. Now, Bandini taps take care of your health too! This is because Bandini has introduced the Ruveco© \*\* process into its production system. This process removes lead from the brass surfaces of the tap. Tests \*\*\* on water drawn from Bandini taps show lead concentrations to be lower than 10 micrograms/litre (well below the maximum threshold recommended by WHO). An excellent result, then, especially when compared to results obtained with untreated taps, which release lead concentrations of between 100 and 120 micrograms/litre!

Bandini Rubinetterie prides itself on offering customers products that are safe and reliable: it should thus come as no surprise that Bandini was one of the first European firms to adopt the process and the first in Italy to systematically apply the Ruveco© process to all its products\*.

\* Only those with our green tap logo.

\*\* Patented in Italy by the "RUVARIS" Research & Development laboratory, a specialist in new technologies applicable to valves and taps.

\*\*\* Tests made in the Ruvaris laboratory.

#### BESCHEINIGUNG GRÜNE-ARMATUR

Die Bandini-Armaturen zeichnen sich seit jeher durch hohe Qualität, ausgereifte Technologie und ansprechendes Design aus. Außerdem schützen sie ihre Gesundheit, da unsere Armaturen dem Ruveco-System©\*\* unterzogen werden. Hierbei handelt es sich um ein Behandlungsverfahren, durch welches das Blei, das sich auf der Oberfläche der Messingteile der Armatur befindet, entfernt wird. Kontrolltests\*\*\* mit Wasser, das an den mit dem Ruveco-System© behandelten Armaturen entnommen wurde, haben bewiesen, dass eine Bleiabgabe festgestellt werden kann, die weit unter 10 Mikrogramm/Liter liegt (von OMS empfohlener Höchstgrenzwert). Ein einzigartiges Ergebnis, vor allem im Vergleich zu nicht behandelten Armaturen, bei denen sich eine Bleiabgabe in Höhe von 100–120 Mikrogramm/Liter feststellen lässt.

Bandini-Armaturen zählt mit zu den ersten Unternehmen Europas, die dieses Behandlungsverfahrens anwenden, denn wir möchten unseren Kunden stets sichere und fortschrittliche Produkte auf dem neuesten Stand bieten. Bandini-Armaturen ist das erste Unternehmen in Italien, das den Ruveco©-Bleientzugsprozess systematisch an allen seinen Produkte anwendet\*.

\* Nur die mit dem entsprechenden Markenzeichen versehenen Produkte.

\*\* In Italien durch das Forschungs und Entwicklungslabor "Ruvaris" patentiert, das auf die Untersuchung neuer Technologien spezialisiert ist, die sich an Ventilen und Armaturen anwenden lassen.

\*\*\* Vom Ruvaris-Labor ausgeführte Tests.

#### CERTIFICATION "ROBINET VERT"

Les robinets Bandini offrent depuis toujours qualité, technologie et design. Ils contribuent à préserver votre santé, parce qu'ils sont soumis au système Ruveco ©\*\* un traitement qui élimine le plomb de la superficie des parties en cuivre du robinet. Les tests de contrôle\*\*\* sur l'eau prélevée des robinets traités avec le système Ruveco© ont démontré une présence de plomb bien inférieure à 10 micro grammes/litre (seuil maximal conseillé par l'OMS). Un résultat exceptionnel, d'autant plus lorsqu'on le compare à celui des robinets non traités. Ces derniers, libèrent en effet, une quantité de plomb égale à 100–120 micro grammes/litre.

Bandini Robinetteries figure parmi les premières sociétés en Europe qui utilisent ce traitement, afin de proposer à ses clients, des produits sûrs et à l'avant-garde. Bandini Robinetteries est le premier fabricant en Italie à appliquer systématiquement le procédé de déplombage Ruveco© sur tous les produits\*.

\* Seulement ceux qui présentent le logo spécifique.

\*\* Breveté en Italie par le laboratoire de Recherche et de Développement "Ruvaris", spécialisé dans l'étude des nouvelles technologies à appliquer aux vannes et robinets.

\*\*\* Tests effectués par le laboratoire Ruvaris

## CONDIZIONI GENERALI DI VENDITA

1. Con il conferimento dell'ordine il cliente accetta pienamente e tacitamente tutte le nostre condizioni di vendita e di consegna sottostanti.
2. I prezzi si intendono per merce resa franco nostro stabilimento di Pelago. I prezzi dei nostri listini sono soggetti a variazioni e non sono impegnativi. Ogni ordine comunque conferito potrà essere ritenuto valido solo se da noi accettato.
3. I termini di pagamento specificati in fattura si intendono tassativi: ogni variazione, che non sia stata preventivamente ed espressamente pattuita, verrà respinta. Sono liberatori solo i pagamenti delle fatture eseguiti al nostro domicilio in Pelago, salvo accordi speciali di pagamenti a termine. Il ritardato pagamento delle forniture darà luogo all'addebito degli interessi bancari. Al verificarsi di pagamenti non eseguiti nei termini convenuti è nostra facoltà sospendere le consegne e gli eventuali ordini già accettati. Si precisa che nessun pagamento potrà essere differito in caso di contestazione. Eventuali aggiunte o modifiche effettuate dal cliente su ordini da lui trasmessi saranno prive di validità se non comunicate in forma scritta.
4. I tempi di consegna si intendono approssimativi e non impegnativi essendo essi vincolati alle possibilità del momento. La mancata osservanza da parte nostra dei termini di consegna indicati, non dà diritto al cliente di annullare l'ordine, diffidare pagamenti o reclamare indennizzi, compensi, penali o danni di sorta. Quanto sopra vale anche nei casi in cui la mancata osservanza dei termini di consegna è conseguente a carenza di materie prime, avarie del macchinario, scioperi, serratte, epidemie, interruzione o ritardi nei trasporti.
5. Consegna merci: la Rubinetterie Bandini si impegna a far ritirare la merce o al vettore di sua fiducia o al vettore indicato dal compratore, per il trasporto alla destinazione indicata dal compratore stesso. In ogni caso, anche quando le spese di trasporto faranno carico alle Rubinetterie Bandini, la merce si intende consegnata al compratore nel luogo di consegna al vettore designato. Dalla rimessa della merce al vettore per il trasporto, il venditore è liberato da ogni rischio e responsabilità relativamente ad essa.
6. La merce viaggia a rischio e pericolo del committente anche se la spedizione è effettuata in porto franco, l'Azienda declina ogni responsabilità per ritardi, guasti, avarie, rotture, ammacchi che si verificassero durante il trasporto. Spetta al committente presentare eventuali reclami al trasportatore, anche se questo è stato scelto dalla Bandini. La Bandini si riserva la facoltà di addebitare al Cliente gli oneri aggiuntivi al puro costo di trasporto (es. soste, operazioni di scarico particolari, ecc.) eventualmente corrisposti al vettore.
7. Tutti i nostri articoli sono accuratamente provati e controllati. La nostra responsabilità sulla qualità del materiale si limita, previa nostra autorizzazione, ad accettare il reso, in porto franco, di pezzi riscontrati difettosi per disporre la sostituzione, senza essere tenuti a corrispondere alcun indennizzo. Non possiamo inoltre accettare alcuna responsabilità ove i materiali da noi forniti risultassero manomessi. Si esclude qualsiasi tipo di risarcimento per danni diretti o indiretti causati dalla posa in opera di materiale difettoso. È fatto assoluto divieto agli acquirenti di effettuare qualsiasi lavorazione ulteriore sui prodotti di nostra produzione. Non riceveremo merce in restituzione se non sarà da noi autorizzata o non sarà inviata con nostro corriere convenzionale.
8. Le illustrazioni dei nostri cataloghi e deplianti hanno lo scopo di dimostrare e rappresentare i singoli articoli e non costituiscono quindi obbligo di fedele esecuzione. I dettagli, le misure ed i pesi indicati sono da considerarsi approssimativi. Pertanto non ci assumiamo alcuna responsabilità in ordine a quanto sopra e conseguentemente non riconosceremo richieste per danni di qualsiasi specie.
9. Per qualsiasi contestazione è sempre e solo competente il foro di Firenze (Italia), anche se gli ordini siano rimessi altrove. Non hanno alcun valore e non vengono da noi riconosciute dichiarazioni, impegnative o garanzie di sorta assunte da nostri dipendenti, agenti o rappresentanti, che non risultano dalle presenti condizioni generali di vendita o da atti ufficialmente sottoscritti dalla Società.
10. Riserva di proprietà. La merce consegnata rimane di riservato dominio della fornitrice fino all'avvenuto pagamento.

## GENERAL TERMS OF SALE

1. Passing the order, the Customer fully and tacitly accepts all the below mentioned sale and delivery terms.
2. Prices are quoted Ex Works. Prices are subject to change and are binding only on the Customer. Every order is valid only after our acceptance.
3. Payment terms in the Invoice are peremptory. Every change that is not previously and expressly agreed will be refused. Payments of Invoice made in our Registered Office are in settlement, apart special agreements for payments on expired date. The delayed payment causes the debit of bank interest. In case of payment effected not in the agreed terms, Bandini reserves to stop the delivery and the already accepted orders. Payment cannot be postponed in case of claim. Eventual variations or additions are accepted only if the notice is written.
4. Delivery time is approximate and not binding since it depends on the possibility at the moment. Our non observance of the delivery time does not entitle the Customer to cancel the order, to postpone payments, to claim damage and compensation. The above mentioned is also valid in case of lack of raw materials, strikes, damages in the machines, epidemics, stop or delay in transport.
5. Rubinetterie Bandini undertakes to have the goods picked up either by its trusted carrier or by the carrier indicated by the buyer, for transportation to the destination indicated by the buyer. In any case, even when the transport expenses are borne by Rubinetterie Bandini, the goods are understood as delivered to the buyer in the place of delivery indicated to the carrier. Starting from the moment when the goods are given to the carrier for the transportation, the seller is free from any risk and responsibility relating to the shipment of the goods themselves.
6. Delivery: Goods are carried at the customer's risk even if shipped free place of destination. We disclaim any responsibility for delays, damages, breakdowns occurred during the transport. The Customer presents possible claims to the carrier, even if it was chosen by Bandini. Bandini reserves to charge additional costs to the Customer at the pure cost of transport eventually due to the carrier.
7. All our products are carefully tested. With reference to the quality of materials, our responsibility is limited to accept the return of goods, upon written authorisation, free collect, for examination. We are not obliged to allow any damages. We cannot accept any responsibility if the materials result to be tampered. We exclude any claim for direct or indirect damages caused by installation of defect materials. It is strictly forbidden to effect any further processing on our products. We do not receive goods on return if they are not authorised and if they are not returned by an agreed carrier.
8. The illustration in our catalogues and brochures show and represent the single articles. We are not obliged to produce them faithfully. The details, sizes and weights are approximate. We decline all responsibility for the above and we do not accept any claims for damages.
9. Any controversy will always be within the competence of the Court of Florence, even if the orders are accepted anywhere. Any statement or warranty not included in this agreement and made by our agents, representatives and workers are no worth and are not recognised by our Company.
10. Reserve of property. The delivered goods are property of the supplier until payment is effected.

## ALLGEMEINE GESCHÄFTSBEDINGUNGEN

1. Mit der Warenbestellung akzeptiert der Kunde vollständig und stillschweigend alle nachstehenden Geschäftsbedingungen der Firma Bandini.
2. Die Preise verstehen sich ab Werk Pelago. Die Listenpreise können sich ändern und sind unverbindlich. Ein Auftrag, wie auch immer erteilt, ist nur gültig, wenn er bestätigt wird.
3. Die in der Rechnung angegebene Zahlungsweise ist verbindlich; jede Abweichung, die nicht vorher ausdrücklich vereinbart wurde, wird nicht akzeptiert. Nur Zahlungen von Rechnungen, die an den Sitz der Gesellschaft in Pelago geleistet werden, wirken befreiend, es sei denn, es wurden besondere abweichende Vereinbarungen bei Terminzahlungen getroffen. Bei verspäteter Zahlung von Lieferungen werden Verzugszinsen berechnet. Bei nicht vereinbarungsgemäß erfolgten Zahlungen behält sich die Firma Bandini vor, die Lieferungen einzustellen und eventuell bereits bestätigte Aufträge nicht auszuführen. Reklamationen rechtfertigen keinen Zahlungsverzug. Eventuelle Ergänzungen oder Änderungen des Auftrags durch den Kunden sind nur in schriftlicher Form gültig.
4. Die genannten Lieferzeiten sind unverbindlich, da sie von den momentan gegebenen Möglichkeiten abhängig sind. Die Nichteinhaltung von angegebenen Lieferzeiten berechtigt den Kunden nicht zur Stornierung des Auftrages, zur Verzögerung der Zahlung, zur Geltendmachung von Entschädigungsleistungen, Ausgleichszahlungen, Strafgeldern oder irgendwelcher Schäden. Dies gilt auch für den Fall, dass die Nichteinhaltung der Lieferfrist durch den Mangel von Rohstoffen, Maschinenschäden, Streiks, Aussperrungen, Epidemien und durch Unterbrechungen oder Verzögerungen beim Transport verursacht wird.
5. Lieferung: Die Rubinetterie Bandini sorgt dafür, dass die Ware entweder von einem Transporteur ihres Vertrauens oder vom Transportunternehmen abgeholt wird, das der Käufer angegeben hat und dann zum vom Käufer angezeigten Bestimmungsort transportiert wird. Auf jeden Fall gilt, auch wenn die Rubinetterie Bandini die Frachtkosten trägt, die Ware dem Käufer an dem Ort zugestellt, die dem Transporteur vorgegeben wurde. Von der Übergabe der Ware an das Transportunternehmen an ist der Verkäufer von jeglichen Risiken und diesbezüglicher Verantwortung entbunden.
6. Der Versand der Ware erfolgt auf Risiko des Käufers, auch wenn er frachtfrei erfolgt. Das Unternehmen übernimmt keine Haftung für Verzögerungen, Schäden, Bruch oder Fehlbestände, die während des Transports entstehen. Der Käufer hat eventuelle Reklamationen direkt an das Transportunternehmen zu richten, auch wenn dieser von der Firma Bandini gewählt wurde. Bandini behält sich die Weiterberechnung von Kosten an den Kunden vor, die über die reinen Transportkosten hinaus anfallen sollten (z.B. Haltezeiten, spezielle Entladungstätigkeiten usw.) und die dem Beförderer eventuell erstattet wurden.
7. Alle Bandini-Produkte sind sorgfältig geprüft und erprobt. Die Haftung hinsichtlich der Produktqualität beschränkt sich auf die frachtfreie Rücknahmen von mangelhaften Teilen zwecks Ersatzlieferung, jedoch nur nach vorheriger Genehmigung, ohne Verpflichtung zu irgendwelchen Entschädigungsleistungen. Weiterhin wird keine Haftung für den Fall übernommen, dass die gelieferten Produkte manipuliert wurden. Jeglicher Schadensersatz für direkte oder indirekte Schäden, die durch den Einbau mangelhafter Teile verursacht wurden, ist ausgeschlossen. Dem Käufer ist es kategorisch untersagt, die Produkte Bandini auf irgendwelche Weise weiter zu bearbeiten. Es wird keine Rückgabe von Ware ohne vorherige Genehmigung durch Bandini akzeptiert. Dies gilt auch für den Fall, dass der Transport nicht durch Vertragsunternehmen der Firma Bandini erfolgt ist.
8. Die Abbildungen in den Bandini-Katalogen und Prospekten haben den Zweck, die Produkte anschaulich darzustellen. Sie beinhalten daher nicht die Verpflichtung zum getreuen Nachbau. Bei den angegebenen Details, Abmessungen und Gewichte handelt es sich um Richtwerte. Es wird daher diesbezüglich keine Verantwortung übernommen und infolgedessen werden keine Ansprüche wegen Schäden irgendwelcher Art anerkannt.
9. Zuständiger Gerichtsstand für Auseinandersetzungen jeglicher Art ist Florenz (Italien), auch wenn der Auftrag woanders erteilt worden ist. Es gilt das Italienische Recht. Keinerlei Gültigkeit haben Erklärungen, Verpflichtungen oder irgendwelche Garantien, die von den Mitarbeitern, Handelsvertretern oder Vertretern der Firma Bandini abgegeben bzw. übernommen wurden, wenn sie nicht mit den vorliegenden allgemeinen Geschäftsbedingungen übereinstimmen oder sich nicht aus offiziell von der Gesellschaft Bandini unterzeichneten Dokumenten ergeben.
10. Eigentumsvorbehalt. Die gelieferte Ware bleibt Eigentum des Herstellers bis zu ihrer vollständigen Bezahlung.

## CONDITIONS GENERALES DE VENTE

1. Par la confirmation de la commande, le client accepte pleinement et tacitement les conditions de vente et de livraison suivantes.
2. Les prix s'entendent franco notre usine de Pelago (Florence). Les prix indiqués dans nos listings sont sujets à variations et ne sont pas obligatoires. Toute commande passée ne sera validée qu'après notre acceptation.
3. Les conditions de paiement spécifiées dans la facture sont obligatoires. Tout changement, qui n'a pas été convenu préalablement et expressément, sera refusé. Seuls les paiements de factures effectués à notre domiciliation bancaire de Pelago sont libératoires, sauf accords spéciaux de paiements à terme. Tout retard dans le paiement des marchandises fournies donnera lieu au versement des intérêts correspondants à la période de retard. Suite à un défaut de paiement, nous nous accordons le droit de suspendre les livraisons et même les éventuelles commandes déjà acceptées. En cas de contestation nous précisons qu'aucun paiement ne pourra être différé. Tout ajout ou modification apportés par le client pour des commandes qu'il a lui-même passées, n'auront aucune validité s'ils n'ont pas été formulés par écrit.
4. Les délais de livraison sont approximatifs et n'engagent pas notre responsabilité puisqu'ils sont liés aux événements momentanés. La non observation de notre part des délais de livraison indiqués, ne donne pas le droit au client d'annuler la commande, de différer le paiement où de réclamer une indemnisation, une compensation, des pénalités ou des dommages de quelque sorte que ce soit. Cela est également valable dans le cas où la non observation des délais de livraison est due à une pénurie de matières premières, à des pannes sur les machines de fabrication, à des grèves y compris patronales, à des épidémies, à des interruptions ou à du retard dans les transports.
5. Clause de livraison: La Rubinetterie Bandini s'engage à faire retirer la merchandise soit du transporteur de confiance soit du transporteur choisi par l'acheteur, pour le transport à la destination indiquée par l'acheteur. En tout cas, même si le transport est payé par Rubinetterie Bandini, la merchandise s'entend livrée aux acheteurs dans le lieu de livraison du transporteur. De la livraison au transporteur pour le transport, le vendeur est déchargé des tous les risques et responsabilité relativement à la même.
6. La marchandise est transportée aux risques du client et ce même si la livraison est en port payé. L'entreprise décline toute responsabilité pour les retards, les pannes, les avaries, les ruptures et les dommages qui peuvent survenir pendant le transport. Il revient au client d'adresser une éventuelle réclamation au transporteur (même dans le cas où celui-ci a été choisi par Bandini). La Bandini se réserve la faculté de facturer au client les frais additionnels au coût du transport(ex. le stationnement, les déchargements particuliers, etc.) qui auraient été payés au transporteur.
7. Tous nos articles ont été sévèrement testés et approuvés avant la vente. Notre responsabilité sur la qualité du matériel se limite, après notre autorisation, à accepter le retour, en port payé, des pièces qui se sont révélées défectueuses pour un remplacement sans aucune indemnisation. Nous ne pouvons pas accepter d'être tenus responsables lorsque les matériaux, que nous avons vendu, ont fait l'objet de dommages. Il n'y aura aucun compensation pour des dommages directs ou indirects causés par la pause de matériel défectueux. Il est absolument interdit aux acheteurs de procéder à des modifications de nos produits. Nous n'accepterons aucun retour de marchandise qui n'aura pas été accepté par nous ou qui ne sera retourné par l'intermédiaire de notre transporteur habituel.
8. Les illustrations de nos catalogues et de nos dépliant ont pour but de montrer et présenter les produits et ne constituent pas une obligation de reproduction fidèle. Les détails, les mesures et les poids indiqués doivent être considérés comme approximatifs. Nous ne sommes donc pas responsables en ce qui concerne ce qui a été dit ci-dessus et par conséquent nous ne tiendrons pas compte d'éventuelles demandes pour des dommages de toute espèce.
9. Pour toute contestation, est toujours et seul compétent le tribunal de Florence (Italie), même si les commandes ont été passées ailleurs. Toutes déclarations, prises en charge ou garanties de tout genre prises par nos employés, agents ou représentants qui ne font pas partie de ces conditions générales de vente ou d'actes officiellement souscrits par la société, n'ont aucune valeur et ne seront pas reconnues.
10. Réserve de propriété. La marchandise livrée reste la propriété réservée du fournisseur tant que le paiement n'a pas été effectué.

# **BANDINI**

RUBINETTERIE

Rubinetterie Bandini srl via Forlivese 134  
50065 Pelago Firenze Italia  
tel + 39 055 8313398/8369830  
fax + 39 055 8316659  
www.rbandini.it info@rbandini.it

**rubinetti/taps/Hähne/robinets**

Xtra GranitiFiandre si riserva la facoltà di modificare in qualunque momento le informazioni e le caratteristiche tecniche illustrate in questo catalogo. I colori e le caratteristiche estetiche dei prodotti sono il più possibile vicino al reale, nei limiti consentiti dai sistemi di stampa.

Xtra GranitiFiandre reserved the right, at any time and without prior notice, to change the information and technical characteristics given in this catalogue. Within the limits of the colors and the aesthetic characteristics of the products illustrated correspond as closely as possible to those of the actual products.

Xtra GranitiFiandre reserviert sich das Recht über die Informations- und technischen Merkmale, in diesem Katalog vor, jederzeit und ohne vorherige Ankündigung. Die Farben und die ästhetischen Merkmale der Produkte die veranschaulicht werden, entsprechen so genau wie möglich den tatsächlichen Produkten.

Xtra GranitiFiandre se réserve le droit de modifier les informations et les caractéristiques techniques illustrées dans le catalogue. Les couleurs et les caractéristiques esthétiques des produits sont les plus possible proches aux celles réelles.